

# LANCOM OW-602

## Quick Reference Guide

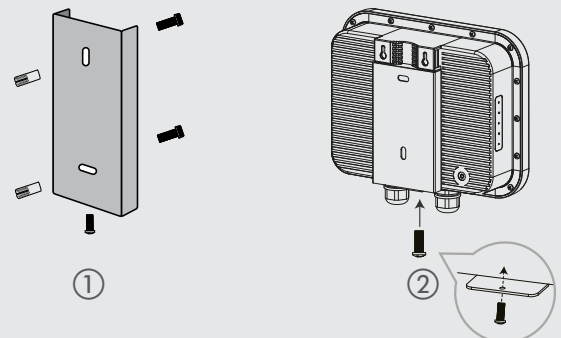

### Mounting



#### Wall mounting

Use the mounting plate ① as a drilling template to mark the drill holes in a sufficiently load-bearing wall. After setting the dowels, align the mounting plate and then fasten it to the wall using the provided M6 screws. Then position the access point in front of the mounting plate as shown in graphic ② and slide it down the guide. Then screw the locking screw from below through the mounting plate into the housing of the access point and tighten it.

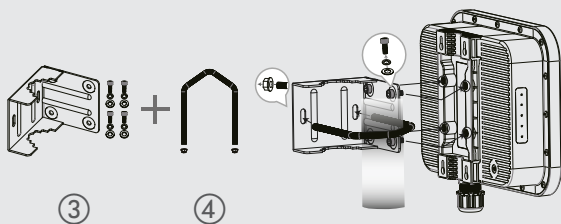

#### Pole mounting

First screw the angle bracket ③ to the access point housing using the provided screws. Note the positioning of the washers and lock washers directly under the screw head. Then position the angle bracket with the screwed-on access point on the mast, guide the bracket ④ around the mast through the holes of the angle bracket and fasten it with the enclosed nuts after aligning the access point.



Installing access points and/or external antennas without adequate lightning protection can lead to serious damage to the devices and/or to the related network infrastructure.

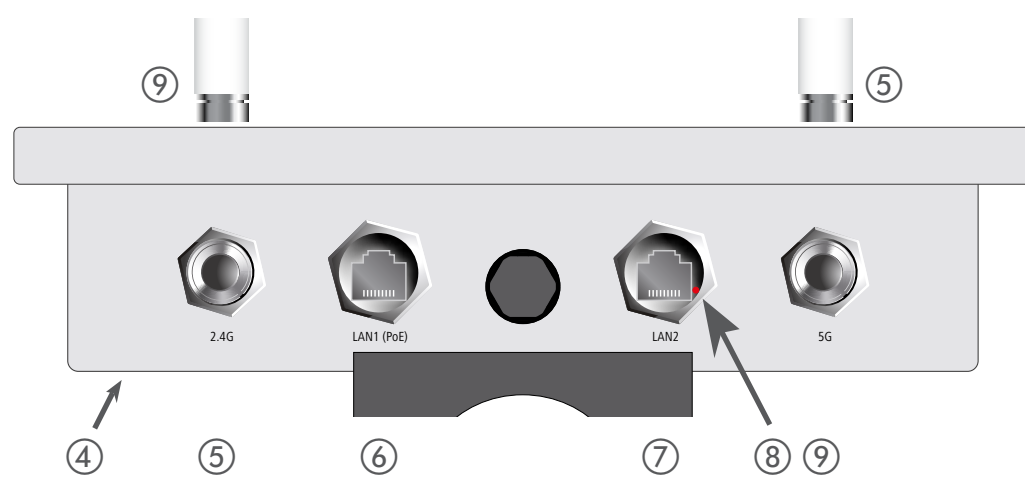

- ④ **Ground connection (bottom of device)**  
Attach the enclosed grounding cable to the housing on one side with the enclosed M3 screw and to a suitable grounding conductor on the other side.
- ⑤ **Antenna connectors 2.4 GHz**  
Screw the supplied 2.4 GHz antennas to the connectors labeled ,2.4G' on the front and back of the device.
- ⑥ **Ethernet interfaces LAN1 (PoE) / LAN2**  
The LAN1 (PoE) port supplies power to the device as well.
- ⑦ Prepare to mount the waterproof Ethernet cable by sliding the end cap ① and then the clamp ring ② over the Ethernet connector ④ on the cable as shown in the adjacent figure. Then place the two seal halves ③ between plug ④ and clamp ring ② on the cable and join them together. Next, insert plug ④ into LAN1 connector ⑤ on the device, carefully push all previously assembled parts towards plug ④ and screw the end cap ① to LAN1 connector ⑤ on the device.  
**Outdoor cable diameter:** 6.5 mm to 8.5 mm  
Connect the other end of the network cable to the ,Power-Out' port of a suitable PoE injector. If required, additionally connect the LAN2 interface to another network device via a waterproof Ethernet cable.
- ⑧ **Reset button (accessible through the housing of the LAN2 socket)**  
To restore the default device configuration, use a suitable pointed object to carefully press the reset button in the device through the recess in the housing of the LAN2 socket until the LEDs on the side of the device go out. During the restart that now follows automatically, the device loads the default configuration.
- ⑨ **Antenna connectors 5 GHz**  
Screw the supplied 5 GHz antennas to the connectors labeled ,5G' on the front and back of the device.

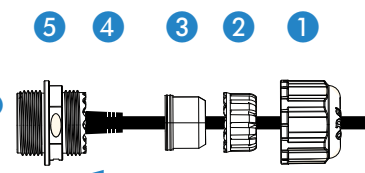

#### Please observe the following when setting up the device

- > The housing of the device may become warm during operation.
- > If the device is operated with outside temperatures exceeding 60 °C, it should be mounted with protection against contact.
- > When using customized outdoor Ethernet cables, make sure that the cables have a short plug kink protection.

Before initial startup, please make sure to take notice of the information regarding the intended use in the enclosed installation guide! Operate the device only with a professionally installed power supply at a nearby power socket that is freely accessible at all times.

MOUNTING AND CONNECTING THE DEVICE

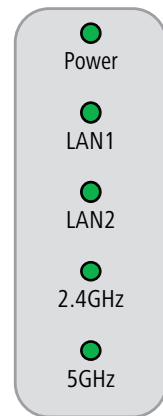

Power	
Off	Device switched off
Green, permanently*	Device operational, resp. device paired / claimed and LANCOM Management Cloud (LMC) accessible
1x green inverse blinking*	Connection to the LMC active, pairing OK, device not claimed
2x green inverse blinking*	Pairing error, resp. LMC activation code not available
3x green inverse blinking*	LMC not accessible, resp. communication error

LAN1 / LAN2	
Off	No networking device attached
Green, permanently	Connection to network device operational, no data traffic
Green, flickering	Data traffic
2.4GHz / 5GHz	
Off	No Wi-Fi network defined or Wi-Fi module deactivated. The Wi-Fi module is not transmitting beacons.
Green	At least one Wi-Fi network is defined and Wi-Fi module activated. The Wi-Fi module is transmitting beacons.
Green, blinking	DFS scanning or other scan procedure

\*) The additional power LED statuses are displayed in 5-seconds rotation if the device is configured to be managed by the LANCOM Management Cloud.

Hardware	
Power supply	Via Power-over-Ethernet compliant to IEEE 802.3at
Power consumption	15.2 W via PoE
Environment	-30 °C to +65 °C
Housing	Robust plastic housing, protection class IP 67, for wall and pole mounting. Note: For installation in salt water environments please use a suitable outer housing. Dimensions 250 x 200 x 80 mm (depth x width x height)
Wi-Fi	
Frequency bands	2.4 GHz and 5 GHz, 2400-2483.5 MHz (ISM) or 5150-5725 MHz (restrictions vary between countries)
Antenna gain	Up to 5 dBi at 2.4 GHz and up to 7 dBi at 5 GHz
Minimum transmission power	Transmission-power reduction in software by 1 dB steps to min. 0.5 dBm
Radio channels 2.4 GHz	Up to 13 channels, max. 3 non-overlapping (2.4-GHz band)
Radio channels 5 GHz	Up to 26 non-overlapping channels (channels available vary according to country regulations; DFS for automatic dynamic channel selection required)
Bluetooth Low Energy	The device can detect BLE devices in the neighborhood and forward the data to external systems for analysis.
Interfaces	
LAN1 (PoE)	10 / 100 / 1000 Mbps auto-sensing, PoE as per IEEE 802.3at
LAN2	10 / 100 / 1000 Mbps autosensing
Wi-Fi	4 NJ ports (2 for 2.4 GHz Wi-Fi module, 2 for 5 GHz Wi-Fi module); BLE: internal antenna
Declaration of conformity	
Hereby, LANCOM Systems GmbH   Adenauerstrasse 20/B2   D-52146 Wuerselen, declares that this device is in compliance with Directives 2014/30/EU, 2014/53/EU, 2014/35/EU, 2011/65/EU, and Regulation (EC) No. 1907/2006. The full text of the EU Declaration of Conformity is available at the following Internet address: <a href="http://www.lancom-systems.com/doc">www.lancom-systems.com/doc</a>	
Package content	
Documentation	Quick Reference Guide (DE/EN), Installation Guide (DE/EN)
Antennas	4 external dipole single-band Wi-Fi antennas (2 for 2.4 GHz and 2 for 5 GHz)
Mounting kit	Equipment for wall and pole mounting, screws included; grounding cable